

# WEDGE CLAMP - Assembly Instructions

Start by marking out the Horizontal Clamp Line (HCL) and Vertical Clamp Line (VCL) lines on sign face, as shown in the Tensioning Method Preparation Sheet.

Trim Sign Face - cut the sign face material leaving 1-1/2" outside the Horizontal Clamp Line (HCL) and the Vertical Clamp Line (VCL) see FIG 3.

To attach the wedge clamp to the sign face, fold the sign face under at the clamp line. Place the wedge clamp bar under the fold at the clamp line. Starting to the right or left of the wedge clamp bar slide the wedge clamp over the flex material, sandwiching the flex material over the wedge clamp bar. Make sure the smaller leg is toward the printed side of the sign face material. (Sign Front)

Attach the teeth clips. To prevent the wedge clamp from sliding off the wedge clamp bar add two teeth clips to the wedge clamp bar. One on each side of wedge clamp, as illustrated below. (FIG. A)

When the wedge clamp is attached to the sign face, place E-Hook and locking nut on the wedge clamp bolt.

Slide the wedge clamp assembly along the break formed receiver (by fabricator). When both the center line of the face and the center line of the sign cabinet align, attach the side and bottom wedge clamp assemblies. Check overall visual appearance.

Tighten the locking nuts on all the E-Hook until distance between the E-Hook and the top of the wedge clamp is approximately 1/2". Always tension the long dimension of any sign face first. Make sure the sign face is free of wrinkles and feels tight. Do not over tighten the sign more than the tension factor.

### IMPORTANT

Check to make certain that the smaller arm on the wedge clamp is toward the printed side of the sign face material as illustrated. (Sign Front)

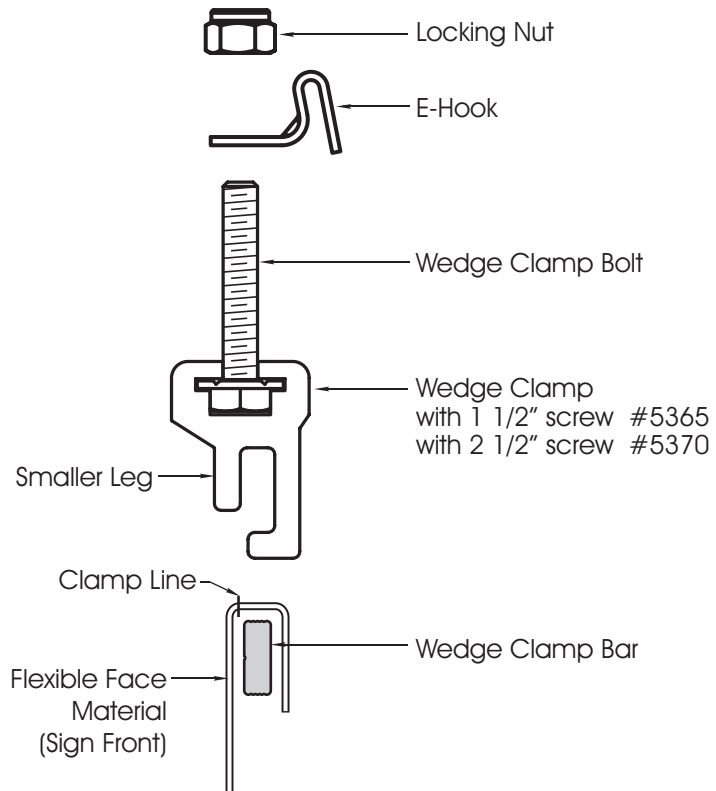

**Wedge Clamp Assembly**

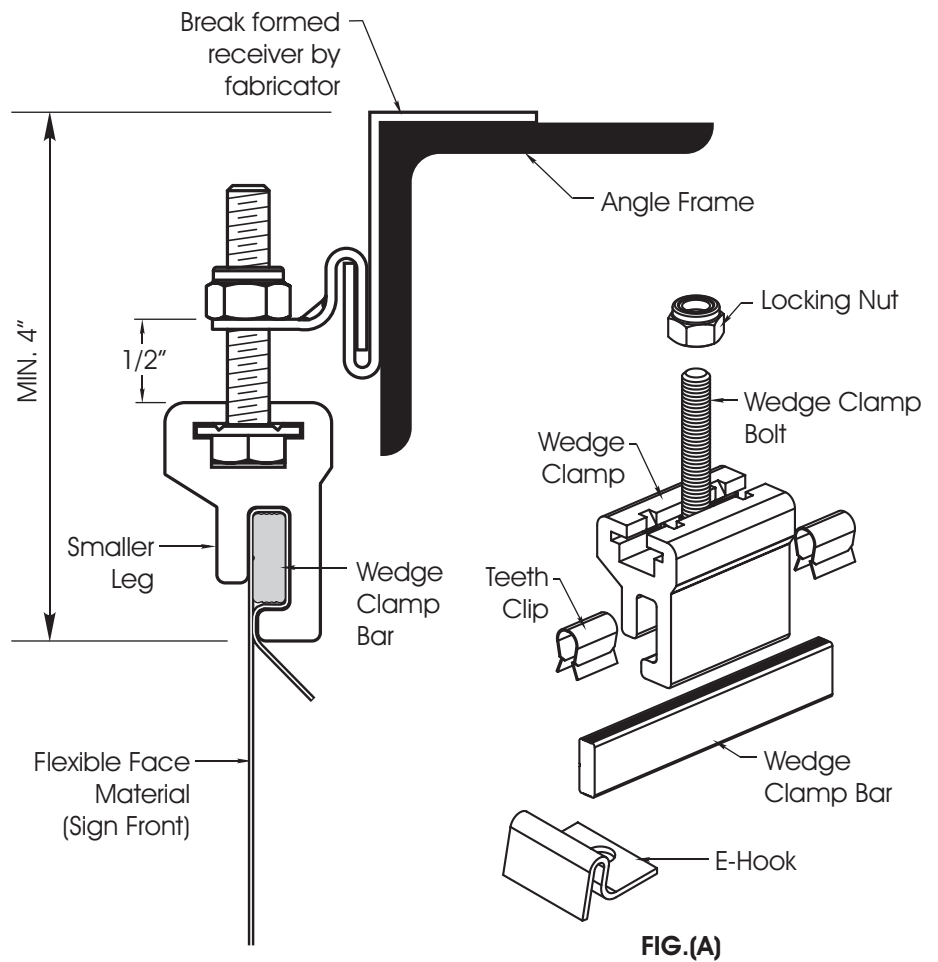

**FIG.(A)**

# WEDGE CLAMP - Tensioning Method Preparation Sheet

## PREPARATION

### (Calculating and Marking Clamp Lines)

#### Tension Factor = (TF)

Deduct 1/16" per linear foot of flexible material.

#### Step 1:

##### Vertical Clamp Line (VCL):

Measure the Receiver Dimensions (RD) in inches (see Fig. 1 or Fig. 2). Subtract 3.5" from the Receiver Dimensions (RD). Then subtract Tension Factor (TF) to determine the Vertical Clamp Line (VCL) FIG. 3.

$$(RD - 3.5") - TF = VCL$$

##### Horizontal Clamp Line (HCL):

Measure the Receiver Dimensions (RD) in inches (see Fig. 1 or Fig. 2). Subtract 3.5" from the Receiver Dimensions (RD). Then subtract Tension Factor (TF) to determine the Horizontal Clamp Line (HCL) FIG. 3.

$$(RD - 3.5") - TF = HCL$$

#### Step 2:

##### Vertical Center (VC):

Divide the Vertical Clamp Line (VCL) by 2 to give the Vertical Clamp Line center of the sign face FIG. 3.

$$VCL / 2 = VC$$

##### Horizontal Center (HC):

Divide the Horizontal Clamp Line (HCL) by 2 to give the Horizontal Clamp Line center of the sign face FIG. 3.

$$HCL / 2 = HC$$

#### Step 3:

##### Sign Face Square Footage (SF):

Multiply the Horizontal Clamp Line (HCL) by the Vertical Clamp Line (VCL) and divide by 144 to give the sign face Square Footage (SF).

$$(HCL \times VCL) / 144 = SF$$

Use the Square Footage (SF) to determine the on center Clamp Spacing (CS) as per FIG. 4.

#### Step 4:

##### Determine total quantity of Wedge Clamps Required (WCR):

Use the Square Footage (SF) and the Clamp Spacing (CS) from Step 3.

Divide the Vertical Clamp Line (VCL) by the Clamp Spacing (CS) and one (1) then Multiply by two (2). This will give you the number of Vertical Wedge Clamps Required (VWCR). Divide the Horizontal Clamp Line (HCL) by the Clamp Spacing (CS) add one (1) then multiply by two (2). This will give you the number of Horizontal Wedge Clamps Required (HWCR). Add the total Horizontal Wedge Clamps Required to the total Vertical Wedge Clamps required this will give you the Wedge Clamps Required (WCR).

$$HWCR + VWCR = WCR$$

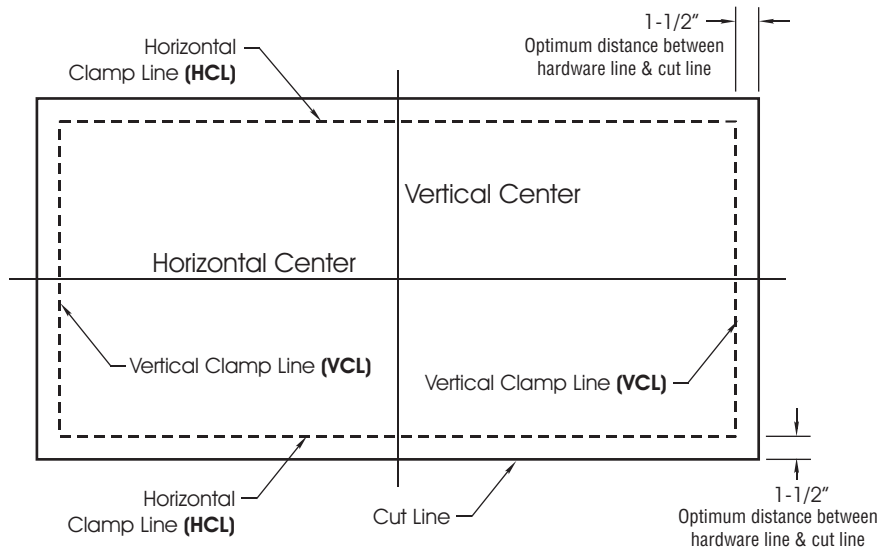

FIG. 3

## Wedge Clamp Attachment Methods

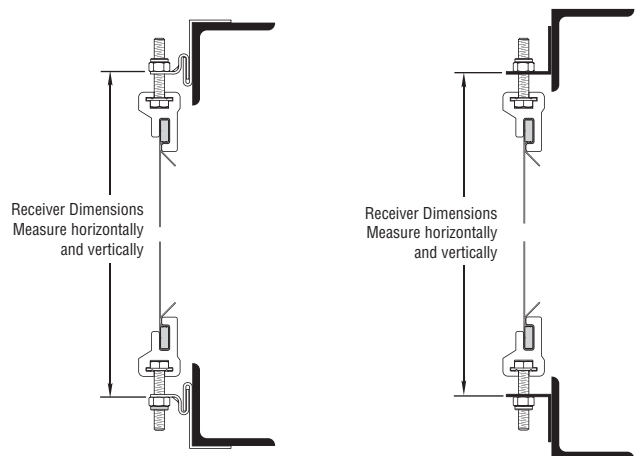

FIG. 1  
E-Hook and Receiver

FIG. 2  
Angle Frame

### Basic 40 psf Wedge Clamp Spacing (CS)

Up to 150 sq. ft.	12" Centers
151 to 300 sq. ft.	10" Centers
301 to 400 sq. ft.	8" Centers
401 to 500 sq. ft.	6" Centers

FIG. 4

For additional technical support please contact SignComp Customer Service at (877) 784-0405.